

Metal Buildings 101

Star describe buildings as Width X Length X Eave Height. The width is the distance along the endwall, gabled or single slope. The length is the distance along the sidewall from endwall to endwall. The width and length of a building is measured from outside face of the girt to the outside face of the girt or steel line to steel line. The eave height is the distance from the finished floor (elevation 100'-0) to the top of the eave strut.

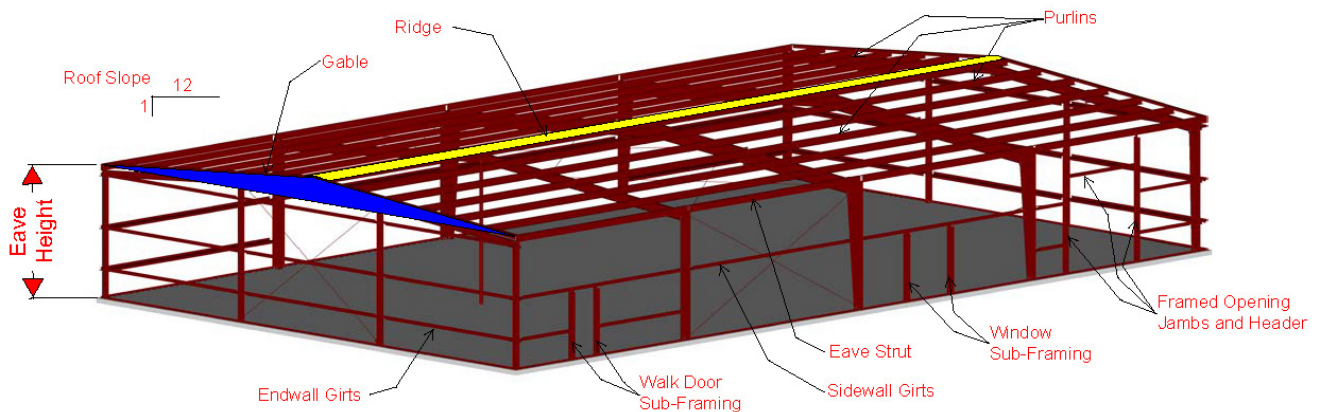

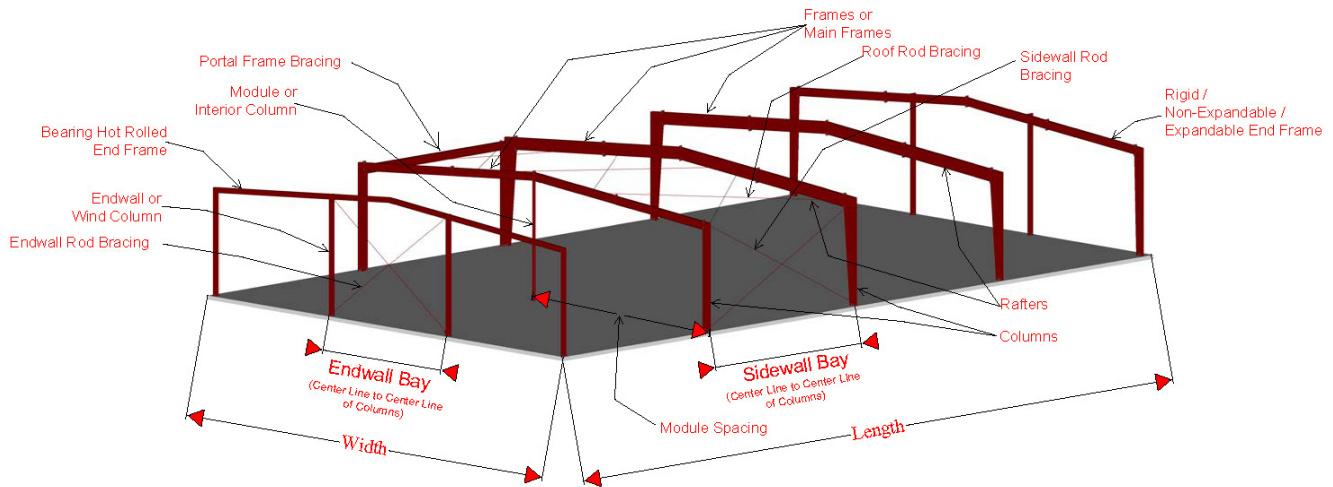

Glossary of Terms Index

- A -

Accessory
Active
Agricultural Building
AISC
AISE
AISI
Aluminum
Aluminum Coated Steel
Anchor Bolt Plan
Anchor Bolts
Anchor Rods
Anodic
ANSI
Approval Drawings
Apron Flashing
Architectural Panel
ASCE
ASCE Rail
ASD
ASHRAE
Asphalt Felt
Assembly
ASTM
Astragal
Automatic Crane
Automatic Welding
Auxiliary Crane Girder
Auxiliary Hoist
Auxiliary Loads
Axial Force

- B -

Bar Joist
Barrel Vault
Base Angle
Base Flashing
Base Plate

Base Tube
Batten
Batten Cover
Batten Seam
Bay
Beam
Beam and Column
Bearing End Frame
Bearing Frame Endwall (BFEW)
Bearing Hot Rolled
Bearing Plate
Bent
Bermuda Seam
Bill of Materials
Bird Screen
Blanket (batt) Insulation
Blind Rivet
BOCA
Box Girder
Bracing
Bracket
Brake
Bridge (Crane)
Bridge Crane
Bridging
British Thermal Unit (BTU)
Builder
Building
Building Aisle
Building Code
Building Envelope
Building Type
Built-Up Roofing
Built-Up Section
Bumper
Butt Plate
Button Punch
Butyl Tape
Bypass Girt

- C -

C Section
Cab-Operated Crane
Camber
Canopy
Cantilever Beam
Cap Plate



Capacity
Capillary Action
Cathodic
Caulk
Caulking
Centerline to Centerline of Runway Beams
C-factor
Channel, Hot Rolled
Cladding
Cleat
Clip
Closure Strip
CMAA
CMRC
Coil Coating
Cold Forming
Cold Rolled
Collateral Loads
Column
Component
Components and Cladding
Concealed Clip
Conditioned Space
Conduction
Conductor Head
Connection
Continuity
Continuous Beam
Contract Documents
Convection
Cool Roof Color
Cooling Degree Day (CDD)
Coped Flashing
Coping
Copper
Cornice
Counterflashing
Covering
Crane
Crane Aisle
Crane Class
Crane Control Type
Crane Girder
Crane Rail
Crane Runway Beam
Crane Span
Crane Stop
Crane Support Column

Crane System Type
CRRC
Curb
Curb, Roof
Curtain Wall

- D -

Damper
Dead Load
Dealer
Deck
Deflection
Design Loads
Design Professional
Dew Point Temperature
Diagonal Bracing
Diaphragm Action
Direct Tension Indicator
Door Guide
Double Lock Standing Seam
Downspout
Drift (Sidesway)
Drift (Snow)
Drift Pin
Drip Edge

- E -

Eave
Eave Gutter
Eave Height
Eave Strut
Edge Strip
Edge Venting
Effective Wind Area
Elastic Design
Electric Operated Crane
Electric Overhead Traveling Crane
End Approach
End Bay
End Frame
End Post
End Stop
End Truck
End Zone
Endwall



Endwall Column
Endwall Overhang
Endwall Type
Energy Cost
Engineer/Architect of Record
EPDM (Ethylene Propylene Diene Monomer)
Erection
Erection Bracing
Erection Drawings
Erector
Expansion Cleat
Expansion Joint
Exterior Framed

- F -

Fabrication
Façade
Fading
Fascia
Felt
Ferrule
Field
Filler Strip
Film Laminated Coil
Fixed Base
Fixed Clip
Flange
Flange Brace
Flashing
Flashing Collar
Floating Clip
Floor Live Load
Flush Frames
Footing
Foundation
Framed Opening
Framing Plans

- G -

G90
Gable
Gable Overhang
Gable Roof
Gage
Galvalume

Galvanic Action
Galvanic Series
Galvanized
Gantry Crane
Gauge
Girder
Girt
Glare
Glaze
Glazing
Grade
Grade Beam
Ground Snow Load
Grout
Gusset Plate
Gutter

- H -

H Section
Hair Pin
Hand-Geared (Crane)
Haunch
Haunch Brace
Header
Heating Degree Day (HDD)
Hem
High Strength Bolts
High Strength Steel
Hinged Base
Hip
Hip Roof
Hoist
Horizontal Guide Rollers
Hot-Rolled Shapes
Hydrokinetic
Hydrostatic

- I -

I Beam
IBC
ICBO
Ice Dam
IECC
Impact Load
Impact Wrench



Importance Factor
Insect Screen
Insulation
Internal Pressure

- J -

Jack Beam
Jack Truss
Jamb
Jib Crane
Jig
Joist

- K -

Kick-Out (Elbow) (Turn-Out)
Kip
Knee
Knee Brace
Knee Cap

- L -

Lap Joint
Lean-To
Length
Leveling Plate
Lift (Crane)
Lifting Devices (Crane)
Liner Panel
Live Load
Load Indicating Washers
Longitudinal
Longitudinal (Crane)
Louver
Low Rise Building
LRFD

- M -

Main Frame
Main Wind Force Resisting System
Mansard
Manufacturer
Manufacturer's Engineer
Masonry

Mastic
Material Safety Data Sheet (MSDS)
MBMA
MCA
Mean Roof Height
Metal Building System
Mezzanine
Mill Duty Crane
Miter
Model Codes
Moment
Moment Connection
Moment of Inertia
Monolithic Construction
Monorail Crane
Multi-Gable Building
Multiple Girder Crane
Multi-Span Building

- N -

NAIMA
NASPEC
NBC
Neoprene
Newton
Noble
Non-Structural Panel

- O -

Oil Canning
Open Web Steel Joists
Order Documents
OSB
Outrigger
Overhanging Beam
Overhead Doors

- P -

Pan
Pan Panel
Panel Notch
Panels
Parapet
Parts and Portions



Pascal
Peak
Peak Sign
Pendant-Operated Crane
Personnel Doors
Piece Mark
Pier
Pig Spout
Pilaster
Pin Connection
Pinned Base
Pitch
Pittsburgh Lock Seam
Plastic Design
Plastic Panels
Ponding
Pop Rivet
Porosity
Portal Frame
Post
Post and Beam
Posttensioning
Power Actuated Fastener
Pre-Painted Coil
Press Brake
Prestressed Concrete
Pretensioning
Primary Framing
Prismatic Beam
Public Assembly
Purlin

- R -

Rafter
Raggle
Rail (Crane)
Rails (Door)
Rake
Rake Angle
Rake Trim
Rated Capacity (Crane)
Reactions
Reglet
Reinforcing Steel
Remote-Operated Crane
Retrofit
Rib

Ribbed Panel
Ridge
Ridge Cap
Rigid Board Insulation
Rigid Connection
Rigid Frame
Rolling Doors
Roll-up Door
Roof Assembly
Roof Covering
Roof Curb
Roof Jack
Roof Live Load
Roof Overhang
Roof Seamer
Roof Slope
Roof Snow Load
Ropeseal
Runway Beam
Runway Bracket
Runway Conductors
R-value (Thermal Resistance)

- S -

S Shape
Sag Member
Sandwich Panel
SBCCI
Screen Wall
Screwed Down Roof System
Scupper
Sealant
Seam
Seaming Machine
Secondary Framing
Section Modulus
Sectional Overhead Doors
Seismic Load
Self Drilling Screw
Self Tapping Screw
Shear
Shear Diaphragm
Sheet Metal Flashing
Shim
Shipping List
Shop Primer Paint
Shot Pin



Shoulder Bolt
SI
Side Lap Fastener
Side Wall
Side Wall Overhang
Sidesway
Sill
Sill Angle
Simple Connection
Simple Span
Single Slope
Single Span
Single Standing Seam
Siphon Break
Sister Column
Skylight
Slide Door
Sliding Clip
Slope
SMACNA
Snap-on Cap
Snow Drift
Snow Load
Snug Tight
Soffit
Soffit Vent
Soil Pressure
Solar Reflectance
Solar Spectrum
Soldier Column
Spacer Strut (Crane)
Spall
Span
Specification (Metal Building System)
Splice
Splice Plate
Spud Wrench
Square
Stainless Steel
Standing Seam
Standing Seam Roof System
Stiffener
Stiffener Lip
Stiles
Stitch Screw
Straight Tread Wheels
Strain
Stress

Structural Panel
Strut
Stud
Substrate
Suspension System
Sustainability
Sweep

- T -

Tapered Members
Tapered Tread Wheels
Temperature Reinforcing
Tensile Strength
Tension Forces
Thermal Block
Thermal Conductance (C-Factor)
Thermal Conductivity (K-Factor)
Thermal Emittance
Thermal Movement
Through Ties
Through-Fastened Roof System
Thrust
Tie
Ton
Torque Wrench
Track
Translucent Light Panels
Transverse
Trapezoidal Panel
Tributary Area
Trim
Trolley (Crane)
Trolley Frame (Crane)
Truss
Turn-of-the-Nut Method
Turnout
Twist Off Bolts

- U -

UBC
Underlayment
Uplift
Urban Heat Island
U-Value (U-Factor)



- V -

Valley
Valley Gutter
Vapor Barrier
Variegated Roof Surface
Vent
Ventilation
Ventilator

- W -

W Section
W Shape
Wainscot
Walk Door
Wall Covering
Web
Web Member
Web Stiffener
Wheel Base
Wheel Load
Width
Wind Bent
Wind Column
Wind Load
Wind Uplift

- X -

X-Bracing

- Z -

Z Section
Zinc-Aluminum Coated



Glossary

- A -

Accessory

A building product that supplements a basic solid panel building such as a door, window, skylight, ventilator, etc.

Active

(Metallurgy) A metal that will corrode in the presence of moisture and a "noble" metal (See Galvanic Action and Galvanic Series Chart in this Glossary).

Agricultural Building

A structure designed and constructed to house farm implements, hay, grain, poultry, livestock or other horticultural products. Such structure shall not include habitable or occupiable spaces, spaces in which agricultural products are processed, treated or packaged; nor shall an agricultural building be a place of occupancy by the general public.

AISC

American Institute of Steel Construction

AISE

Association of Iron and Steel Engineers

AISI

American Iron and Steel Institute

Aluminum

A corrosion resistant metallic element. Aluminum alloy coated sheet is often used for metal roofing and wall panels.

Aluminum Coated Steel

Steel coated with aluminum for corrosion resistance.

Anchor Bolt Plan

A plan view drawing showing the diameter, location and projection of all anchor rods for the components of the Metal Building System and may show column reactions (magnitude and direction). The maximum base plate dimensions may also be shown.

Anchor Bolts

See Anchor Rods.

Anchor Rods

The term "anchor rod" is used for threaded rods embedded in concrete to anchor structural steel. The term "rod" is intended to clearly indicate that these are threaded rods, not structural bolts, and should be designed as threaded parts using the material specified in the latest edition of AISC. The embedded end of the rod may be secured in the concrete by means of a head, threading with a nut on the end, a hook or other deformation, by welding to reinforcing steel or other means.

Anodic

With regard to metal and galvanic response, when two metals are connected in an electrolyte, they will form a galvanic cell, with the higher metal in the galvanic series being the anode. The anodic metal, being more "active" oxidizes first, thus protecting the cathodic metal from corrosion (see cathodic).

ANSI

American National Standards Institute

Approval Drawings

A set of drawings that may include framing plans, elevations and sections through the building for approval of the buyer.

Apron Flashing

A flashing located at the juncture of the top of the sloped roof and a vertical wall or steeper-sloped roof.

Architectural Panel

Any panel that has a primary purpose of the aesthetic enhancement of a building or structure.



ASCE

American Society of Civil Engineers

ASCE Rail

American Society of Civil Engineers rated steel shape similar to a train track. Placed on top of a runway beam, it acts as a guide for top running cranes.

ASD

Allowable Stress Design.

ASHRAE

American Society of Heating, Refrigerating and Air-Conditioning Engineers

Asphalt Felt

An asphalt-saturated and/or an asphalt-coated felt. (See Felt).

Assembly

A group of mutually dependent and compatible components or sub-assemblies of components.

ASTM

American Society for Testing and Materials.

Astragal

A closure between the two leaves of a double swing or double slide door.

Automatic Crane

A crane which when activated operates through a pre-set cycle or cycles.

Automatic Welding

A welding procedure utilizing a machine to make a weld.

Auxiliary Crane Girder

A girder arranged parallel to the main girder for supporting the platform, motor base, operator's cab, control panels, etc., to reduce the torsional forces that such load would otherwise impose on the main crane girder.

Auxiliary Hoist

A supplemental hoisting unit, usually designed to handle lighter loads at a higher speed than the main crane hoist.

Auxiliary Loads

Dynamic live loads such as those induced by cranes and material handling systems.

Axial Force

A force tending to elongate or shorten a member.

- B -

Bar Joist

A name commonly used for "Open Web Steel Joists".

Barrel Vault

A semi-cylindrical shaped roof.

Base Angle

An angle secured to a wall or foundation used to attach the bottom of the wall paneling.

Base Flashing

The lower flashing component of a two component metal flashing detail. The component flashing details are often used either for expedience or to allow differential thermal movement between building elements or accessories. The lower component is the "base" flashing; the upper component is the "counter-flashing".

Base Plate

A plate attached to the bottom of a column that rests on a foundation or other support, usually secured by anchor rods.

Base Tube

A continuous member imbedded in the edge of the foundation to which the wall panels are attached.

Batten

A strip of wood common to non-structural panels that is used to support the vertical ribs of adjacent metal panels.



Batten Cover

1. A separate strip of metal used to cover the wood batten, and join the vertical ribs of adjacent metal panels on either side of the batten.
2. A strip of formed metal used to span the void area and join the vertical legs of adjacent metal panels.

Batten Seam

1. A metal panel profile attached to and formed around a wood or metal batten,
2. A metal panel profile that imitates the traditional batten seam system but omits the wooden batten.

Bay

The space between the main frames measured normal to the frame.

Beam

A member, usually horizontal, that is subjected to bending loads. There are three types, simple, continuous, and cantilever.

Beam and Column

A structural system consisting of a series of rafter beams supported by columns. Often used as the end frame of a building.

Bearing End Frame

See "Beam and Column"

See "Bearing Hot Rolled"

Bearing Frame Endwall (BFEW)

See "Beam and Column"

See "Bearing Hot Rolled"

Bearing Hot Rolled

Also referred to as a Bearing End Frame or Bearing Frame Endwall (BFEW). A Bearing Hot Rolled is a structural system consisting of a series of hot rolled rafter beams supported by hot rolled columns connected by a series of pinned connections. Often used as the end wall framing of a building.

See "Beam and Column"

Bearing Plate

A steel plate that is set on the top of a masonry support on which a beam or purlin can rest.

Bent

See "Main Frame".

Bermuda Seam

A metal panel featuring a stepped profile. The panel runs perpendicular to the slope of the roof.

Bill of Materials

A list that enumerates by part number or description each piece of material or assembly to be shipped.

Also called tally sheet or shipping list.

Bird Screen

Wire mesh used to prevent birds from entering the building through ventilators and louvers.

Blanket (batt) Insulation

A layer or sheet of flexible fiberglass thermal insulation.

Blind Rivet

A small headed pin with expandable shank for joining light gage metal. Typically used to attach flashing, gutter, etc.

BOCA

Building Officials and Code Administrators International, Inc.

Box Girder

Girders, trucks or other members of rectangular cross-section enclosed on four sides.

Bracing

Rods, angles or cables used in the plane of the roof and walls to transfer loads, such as wind, seismic and crane thrusts to the foundation.

Bracket

A structural support projecting to a structural member. Examples are canopy brackets, lean-to brackets, and crane runway brackets.



Brake

A machine used to bend, fold or form sheet metal.

Bridge (Crane)

That part of an overhead crane consisting of girders, trucks, end ties, walkway and drive mechanism which carries the trolley and travels in a direction parallel to the runway.

Bridge Crane

A load lifting system consisting of a hoist that moves laterally on a beam, girder or bridge, which in turn moves longitudinally on a runway, made of beams and rails.

Bridging

Bracing or systems of bracing used between structural members.

British Thermal Unit (BTU)

That amount of heat required to raise the temperature of one pound of water by 1°F.

Builder

A party who, as a routine part of his business, buys the Metal Building System from a manufacturer for the purpose of resale. See "Dealer"

Building

A structure forming an open, partially enclosed, or enclosed space constructed by a planned process of combining materials, components, and subsystems to meet specific conditions of use.

Building Aisle

A space defined by the length of the building and the space between building columns.

Building Code

Regulations established by a recognized agency describing design loads, procedures and construction details for structures usually applying to a designated political jurisdiction (city, county, state, etc.).

Building Envelope

The elements of a building that enclose conditioned spaces through which thermal energy is capable of being transferred.

Building Type

There are two types of Buildings "Stand Alone" buildings and "Attachment" buildings.

Stand Alone

A Stand Alone building is any building in a project that does not attach to any other building in the same project. The first building entered in a new project is always a Stand Alone building because there are no other building to which it could attach. A Stand Alone building can be added to the project and located so that it does not interfere with other buildings in the project.

Attachment

An Attachment is a building which will attach to any other building in the project. An attachment can be a Lean-to, single slope or gabled building. Attachments can be made Endwall-to-Endwall, Sidewall-to-Sidewall, Endwall-to-Sidewall or Sidewall-to-Endwall. The frames of an attachment that is a lean-to must line up with the columns lines of the building to which it attaches. Any other building type can attach to another building anywhere along the wall to which it attaches.

Built-Up Roofing

A roof covering made up of alternating layers of tar and asphaltic materials or layers (plies) of organic or synthetic fabric.

Built-Up Section

A structural member, usually an I-shaped section, made from individual flat plates welded together.

Bumper

An energy-absorbing device for reducing impact when a moving crane or trolley reaches the end of its permitted travel; or when two moving cranes or trolleys come into contact.

Butt Plate

The end plate of a structural member usually used to rest against a like plate of another member in forming a connection. Sometimes called a splice plate or bolted end plate.

Button Punch

A process of indenting two or more sheets of metal that are pressed against each other to prevent slippage between the metal.



Butyl Tape

A common abbreviation for polyisobutylene-isoprene polymer sealant tape used between metal roof panel and flashing joints.

Bypass Girt

See "Exterior Framed".

- C -

"C" Section

A member formed from steel sheet in the shape of a block "C", that may be used either singularly or back to back.

Cab-Operated Crane

A crane controlled by an operator in a cab supported on the bridge or trolley.

Camber

Curvature of a flexural member in the plane of its web before loading.

Canopy

A projecting roof system that is supported and restrained at one end only.

Cantilever Beam

A beam supported only at one end having a free end and a fixed end.

Cap Plate

A plate located at the top of a column or end of a beam for capping the exposed end of the member.

Capacity

The maximum load (usually stated in tons) that a crane is designed to support.

Capillary Action

That action which causes movement of liquids when in contact with two adjacent surfaces such as panel sidelaps.

Cathodic

With regard to metal and galvanic response, cathodic metals are lower (and more noble) in the galvanic series. (May be protected from oxidation by more anodic metals). (See "Anodic").

Caulk

See "Sealant".

Caulking

Filling the joints, seams or voids between adjacent units with a sealant in order to make them weathertight.

Centerline to Centerline of Runway Beams

The span of a crane system. Also referred to as Centerline to Centerline of Rail

Channel, Hot Rolled

A C-shaped member formed while in a semi-molten state at the steel mill to a shape having standard dimensions and properties.

Cladding

The exterior metal roof and wall paneling of a Metal Building System. See also "Components and Cladding".

Cleat

A sheet metal strip used in concealed fashion to secure panels or flashing that permits some limited degree of thermal response.

Clip

A plate or angle used to fasten two or more members together.

Closure Strip

A resilient strip, formed to the contour of ribbed panels and used to close openings created by ribbed panels joining other components.

CMAA

Crane Manufacturers of America Association, Inc. An independent trade association in the United States. It is affiliated with the United States Division of Material Handling Industry. It is a voluntary association to



help promote the standardization of cranes as well as uniform quality and performance.

CMRC

Cool Metal Roofing Coalition.

Coil Coating

The application of a finish to a coil of metal sheet using a continuous mechanical coating process.

Cold Forming

The process of using press brakes or rolling mills to shape steel into desired cross sections at room temperature.

Cold Rolled

The process of forming sheet steel into desired shapes on a series of rollers at ambient room temperatures.

Collateral Loads

The weight of additional permanent materials required by the contract, other than the Building System, such as sprinklers, mechanical and electrical systems, partitions and ceilings.

Column

A main member used in a vertical position on a building to transfer loads from main roof beams, trusses, or rafters to the foundation.

Component

A part used in a Metal Building System. See also "Components and Cladding".

Components and Cladding

For wind load considerations, members that do not qualify as part of a Main Wind Force Resisting System. They include girts, joists, purlins, studs, wall and roof panels, fasteners, end wall columns and end wall rafters of bearing end frames, roof overhang beams, canopy beams, and masonry walls when acting as other than shear walls.

Concealed Clip

A hold down clip used with a wall or roof panel system to connect the panel to the supporting structure without exposing the fasteners on the exterior surface.

Conditioned Space

1. Cooled space: an enclosed space within a building that is cooled by a cooling system whose sensible output capacity is greater than or equal to 5 Btu/h-ft of floor area.
2. Heated space: an enclosed space within a building that is heated by a heating system whose output capacity is greater than or equal to 5 Btu/h-ft of floor area.
3. Semi-heated space: an enclosed space within a building that is heated by a heating system whose output capacity is greater than or equal to 3.4 Btu/h-ft of floor area but is not a conditioned space.

Conduction

The transfer of heat through a material or construction.

Conductor Head

A transition component between a through-wall scupper and downspout used to collect and direct run-off water.

Connection

The means of attachment of one structural member to another.

Continuity

The terminology given to a structural system denoting the transfer of loads and stresses from member to member as if there were no connections.

Continuous Beam

A beam of variable geometry passing over two supports with overhang on one end or passing over three supports.

Contract Documents

The Documents that define the material and work to be provided by a Contractor or the General Contractor for a Construction Project.

Convection

The heating of the air that passes over a hot surface.



Cool Roof Color

The color coating on or self color of the roofing material that gives it a high solar reflectance and a high thermal Emittance.

Cooling Degree Day (CDD)

The difference in temperature between the outdoor mean temperature over a 24-hour period and a given base temperature. For example, using a base temperature of 65° F a day with 85° F mean temperature has 20 CDD (85-65=20). The annual Cooling Degree Days are the sum of the degree days over a calendar year.

Coped Flashing

A sheet metal flashing, cut or formed to the contour of ribbed panels and used to close openings created by ribbed panels joining other components.

Coping

The covering piece on top of an exposed wall or parapet usually made of metal, masonry or stone. It is often sloped to shed water back onto the roof.

Copper

A natural weathering metal used in architectural metal roofing; typically used in 16 or 20 oz. per square foot thickness (4.87 or 6.10 kg/square meter)

Cornice

A decorative finish or flashing that accents the top of a wall, or the juncture of a roof and wall.

Counterflashing

Formed metal or elastomeric flashing secured on or into a wall, curb, pipe, rooftop unit, or other surface, to cover and protect the upper edge of the base flashing and its associated fasteners from exposure to the weather.

Covering

See "Cladding."

Crane

A machine designed to move material by means of a hoist.

Crane Aisle

This is the section of the building serviced by the crane. The aisle length can run the length of the building (perpendicular to frames) or it can run across (parallel to frames). The width of the aisle is based on the width of the crane bridge unless it is a monorail and then it is simply a line.

Crane Class

Crane Manufacturers of America Association (CMAA) has established six categories of crane service classification as a guide for determining the service requirements of a specific crane application. For more information about Crane Service Classifications, see the MBMA handbook section II, subsection 2.9.1

- **Class A (Standby or infrequent use)** This service class covers cranes used in installations such as powerhouses, public utilities, turbine rooms, motor rooms and transformer stations where precise handling of equipment at slow speeds with long, idle periods between lifts are required. Capacity loads are handled for initial installation of equipment and for infrequent maintenance.
- **Class B (Light Service)** This service class covers cranes used in repair shops, light assembly operations, service buildings, light warehousing, etc. where service requirements are light and the speed is slow. Loads vary from no load to occasional full rated loads with two to five lifts per hour, averaging 10 feet per lift.
- **Class C (Moderate Service)** This service class covers cranes used in machine shops or paper mill machine rooms, etc. where service requirements are moderate. In this type of service, the crane handles loads that average 50 percent of the rated capacity with five to ten lifts per hour, averaging 15 feet, not over 50 percent of the lifts at rated capacity.
- **Class D (Heavy service)** This service class covers cranes used in heavy machine shops, foundries, fabricating plants, steel warehouses, container yards, lumber mills, etc., and the standard duty bucket and magnet operations where heavy duty production is required. In this type of service, loads approaching 50 percent of the rated capacity are handled constantly during the working period. High speeds are used for this type of service with 10 to 20 lifts per hour averaging 15 feet, not over 65 percent of the lifts at rated capacity.



- **Class E (Severe service) (Mill Duty)** This type of service requires a crane capable of handling loads approaching a rated capacity throughout its life. Applications may include magnet, bucket, magnet/bucket combination cranes for scrap yards, cement mills, lumber mills, fertilizer plants, container handling, etc., with twenty or more lifts per hour at or near the rated capacity.
- **Class F (Continuous severe service) (Mill Duty)** This type of service requires a crane capable of handling loads approaching rated capacity continuously under severe service conditions throughout its life. Applications may include custom designed specialty cranes essential to performing the critical work tasks affecting the total production facility. These cranes must provide the highest reliability with special attention to ease of maintenance features.

Crane Control Type

The method by which the crane is controlled.

Crane Girder

The principal horizontal beams of the crane bridge which supports the trolley and is supported by the end tracks.

Crane Rail

A track supporting and guiding the wheels of a bridge crane or trolley system. On underhung cranes, the crane rail also acts as the runway beam.

Crane Runway Beam

The member that supports a crane rail and is supported by columns or rafters depending on the type of crane system. On underhung bridge cranes, the runway beam also acts as the crane rail.

Crane Span

The horizontal distance center-to-center of runway beams.

Crane Stop

A device to limit travel of a trolley or crane bridge. This device normally is attached to a fixed structure and normally does not have energy-absorbing ability.

Crane Support Column

A column that sets under the runway beam and next to frame column with bracing to frame column for lateral support.

Crane System Type

1. Top Running (TRE) (Top Running Electric)
2. Underhung (UHE) (Underhung Electric) - Typically crane capacities up to about 15 tons
3. Monorail - Typically crane capacities up to about 10 tons

CRRC

Cool Roof Rating Council.

Curb

A raised edge on a concrete floor slab.

Curb, Roof

An element used to raise a wall, flashing or accessory item above the drainage plane of a roof.

Curtain Wall

Perimeter wall panels that carry only their own weight and wind load.

- D -

Damper

A baffle used to open or close the throat of ventilators.

Dead Load

The weight of the Building System construction consisting of members such as framing and covering.

Dealer

See "Builder".

Deck

A flat structural element that is fastened to the roof framing members, typically corrugated metal sheets or plywood. It acts as the substrate for non-structural roof panels.

Deflection

The displacement of a structural member relative to its supports due to applied loads. Deflection should not be confused with "Drift".

Design Loads

The loads expressly specified in the contract documents that the Metal Building System is designed to safely resist.

Design Professional

The Architect or Engineer responsible for the design of a Construction Project.

Dew Point Temperature

The temperature at which water vapor condenses in cooling air at the existing atmospheric pressure and vapor content. Cooling air below the dew point will cause condensation.

Diagonal Bracing

See "Bracing".

Diaphragm Action

The resistance to racking generally offered by the panels, fasteners, and members to which they are attached.

Direct Tension Indicator

See "Load Indicating Washer".

Door Guide

An angle or channel used to stabilize or keep plumb a sliding or rolling door during its operation.

Double Lock Standing Seam

A standing seam in which the female component of the seam is wrapped and folded approximately 360 degrees around the male seam component. (The male component is interlocked and usually folded 180 degrees). See "Standing Seam".

Downspout

A vertical conduit used to carry runoff water from a scupper, conductor head or gutter of a building to a lower roof level, or to the ground or storm water runoff system.

Drift (Sideway)

Horizontal displacement at the top of a vertical element due to lateral loads. Drift should not be confused with "Deflection".

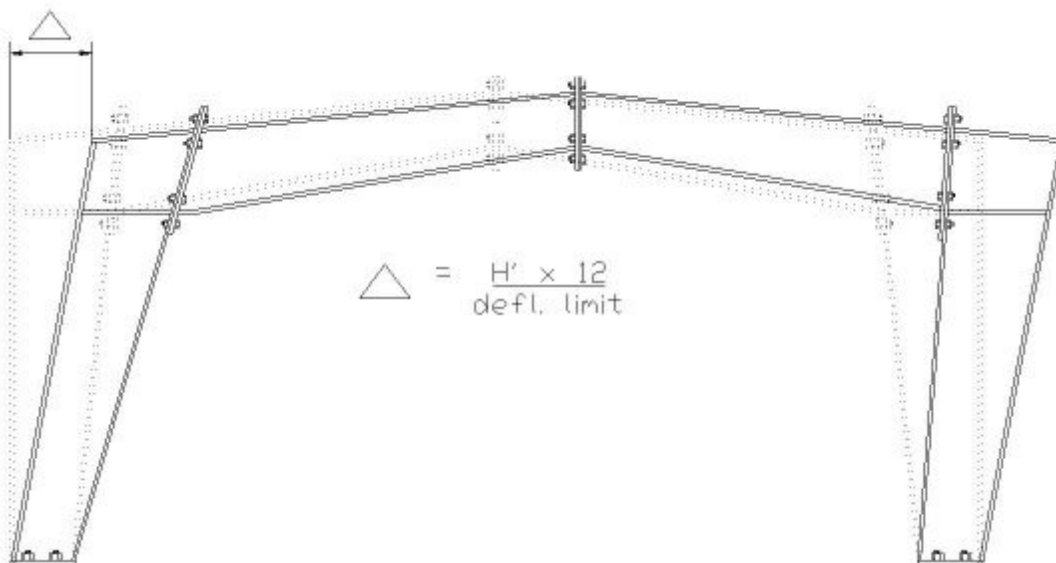

Drift (Snow)

The snow accumulation at a height discontinuity.



Drift Pin

A tapered pin used during erection to align holes in steel members to be connected by bolting.

Drip Edge

A metal flashing, with an outward projecting lower edge, intended to control the direction of dripping water and to protect underlying building components.

- E -

Eave

The line that is usually parallel to the ridge line formed by the intersection of the planes of the roof and wall.

Eave Gutter

See "Gutter".

Eave Height

The vertical dimension from finished floor to the eave.

Eave Strut

A structural member located at the eave of a building that supports roof and wall paneling and may act as a strut to transfer bracing loads to frames.

Edge Strip

The surface area of a building at the edges of the roof and at the wall intersections where the wind loads on components and cladding are greater than at other areas of the building.

Edge Venting

The practice of providing regularly spaced or continuous openings along a roof edge or perimeter, used as part of a ventilation system to dissipate heat and water vapor.

Effective Wind Area

The area used to determine the wind coefficient. The effective wind area may be greater than or equal to the tributary area.

Elastic Design

A design concept utilizing the proportional behavior of materials when all stresses are limited to specified allowable values in the elastic range.

Electric Operated Crane

A crane in which the bridge, hoist or trolley is operated by electric power.

Electric Overhead Traveling Crane

An electrically-operated machine for lifting, lowering and transporting loads, consisting of a movable bridge carrying a fixed or movable hoisting mechanism and traveling on an overhead runway structure.

End Approach

The minimum horizontal distance, parallel to the runway, between the outermost extremities of the crane and the centerline of the hook.

End Bay

The bays adjacent to the endwalls of a building. Usually the distance from the endwall to the first interior main frame measured normal to the endwall.

End Frame

A frame located at the endwall of a building that supports the loads from a portion of the end bay.

End Post

See "End Wall Column".

End Stop

Bumpers or wheel stops attached to the end of the crane runway to prevent the crane from driving off the end of the runway. These are provided by the rail vendor only.

End Truck

The unit consisting of truck frame, wheels, bearings, axles, etc., which supports the bridge girder(s) and allows movement along the length of the runway structure.

End Zone

The surface area of a building along the roof at the endwall and at the corners of walls



Endwall

An exterior wall that is parallel to the interior main frame of the building.

Endwall Column

A vertical member located at the endwall of a building that supports the girts. In beam and column end frames, endwall columns also support the beam. Also referred to as a "Wind Column"

Endwall Overhang

The projection of the roof beyond the plane of the endwall.

Endwall Type

Refers to the type of framing that is used at and endwall.

Energy Cost

The total estimated annual cost for purchased energy for the building, including any demand charges, fuel adjustment factors and delivery charges applicable to the building.

Engineer/Architect of Record

The engineer or architect who is responsible for the overall design of the building project. The manufacturer's engineer is typically not the Engineer of Record.

EPDM (Ethylene Propylene Diene Monomer)

A Synthetic thermoset rubber that is popular for membrane roofing and flashings, and as gasketing material for the head of weather sealing screw fasteners.

Erection

The on-site assembling of fabricated Metal Building System components to form a completed structure.

Erection Bracing

Materials used by erectors to stabilize the building system during erection.

Erection Drawings

Roof and wall erection (framing) drawings that identify individual components and accessories furnished by the manufacturer in sufficient detail to permit proper erection of the Metal Building System.

Erector

A party who assembles or erects a Metal Building System.

Expansion Cleat

A cleat designed to accommodate thermal movement of the metal roof panels.

Expansion Joint

A break or space in construction to allow for thermal expansion and contraction of the materials used in the structure.

Exterior Framed

A wall framing system where the girts are mounted on the outside of the columns.

- F -

Fabrication

The manufacturing process performed in a plant to convert raw material into finished Metal Building System components. The main operations are cold forming, cutting, punching, welding, cleaning and painting.

Façade

An architectural treatment, partially covering a wall, usually concealing the eave and/or the rake of the building.

Fading

Any loss of initial color intensity.

Fascia

A decorative trim or panel projecting from the face of a wall.

Felt

A flexible sheet manufactured by the interlocking of fibers through a combination of mechanical work, moisture and heat. Roofing felts may be manufactured principally from wood pulp and vegetable fibers (organic felts), asbestos fibers (asbestos felts), glass fibers (fiberglass felts or plysheet), or polyester fibers.



Ferrule

A small metal sleeve placed inside a gutter at the top. In residential applications, a spike is nailed through the gutter into the fascia board to hold the gutter in place. The ferrule acts as a spacer in the gutter to maintain its original shape.

Field

1. The uninterrupted principle area of a roof, exclusive of edges, accessory and other flashing areas.
2. The "job site" or "building site".
3. General marketing area.

Filler Strip

See "Closure Strip".

Film Laminated Coil

Coil metal that has a corrosion resistant film laminated to it prior to the forming operation.

Fixed Clip

A standing seam roof system hold down clip that does not allow the roof panel to move independently of the roof substructure.

Fixed Base

A column base that is designed to resist rotation as well as horizontal or vertical movement.

Flange

The projecting edge of a structural member.

Flange Brace

A member used to provide lateral support to the flange of a structural member.

Flashing

See "Trim".

Flashing Collar

A counterflashing used to cover and/or seal the top of a pipe flashing or other small base flashing at penetrations through the roof.

Floating Clip

See "Sliding Clip".

Floor Live Load

Those loads induced on the floor system by the use and occupancy of the building.

Flush Frames

A wall framing system where the outside flange of the girts and the columns are flush.

Footing

A pad or mat, usually of concrete, located under a column, wall or other structural member, that is used to distribute the loads from that member into the supporting soil.

Foundation

The substructure that supports a building or other structure.

Framed Opening

Framing members and flashing that surround an opening.

Framing Plans

See "Erection Drawings".

- G -

G90

A typical coating weight for galvanized metal sheet. Equates to 0.90 oz. (26g) of zinc per square foot, measured in both front and back surfaces. Other coating weights are G30 and G60.

Gable

The triangular portion of the endwall from the level of the eave to the ridge of the roof.

Gable Overhang

See "End Wall Overhang".

Gable Roof

A roof consisting of two sloping sides that form a ridge and a gable at each end.



Gage

The distance between adjacent lines of fasteners along which pitch is measured, or the distance from the back of an angle or other shape to the first line of fasteners.

Galvalume®

A proprietary trade name for a coating, used over sheet steel, that is composed of an aluminum-zinc alloy for corrosion protection.

Galvanic Action

An electrochemical reaction between dissimilar metals in the presence of an electrolyte.

Galvanic Series

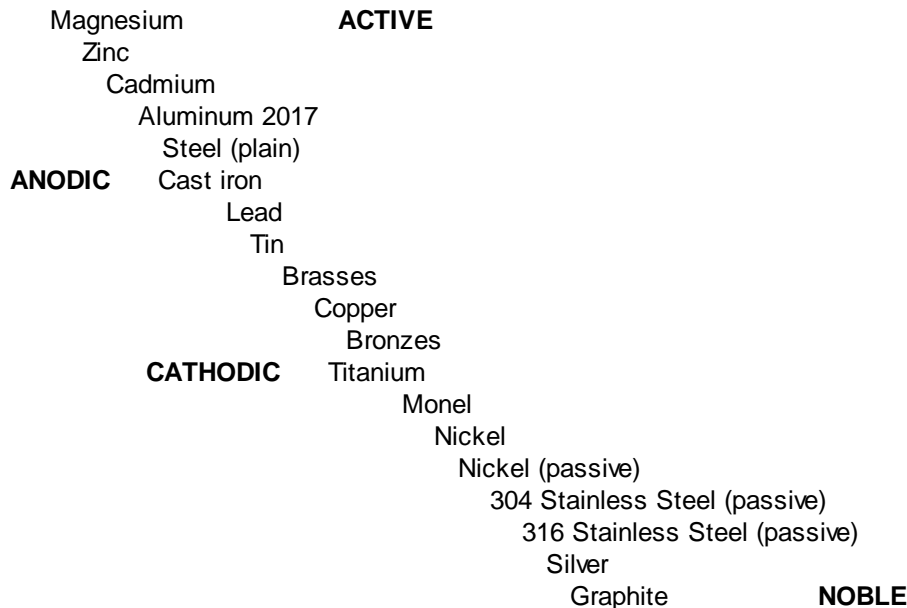

Galvanized

Steel coated with zinc for corrosion resistance.

Gantry Crane

A crane similar to a top running crane except one side of the bridge is supported by one or more gantry legs that ride on a rail attached to the floor, while the other side's end truck rides on a runway beam.

Gauge

The thickness of sheet metal.

Girder

A main horizontal or near horizontal structural member that supports vertical loads. It may consist of several pieces.

Girt

A horizontal structural member that is attached to sidewall or endwall columns and supports paneling.

Glare

The reflection of sunlight that can impair vision and create an annoyance. Glare of a coated surface is controlled by the sheen. Low Sheen = Low Glare.

Glaze

The process of installing glass in windows and doors.

Glazing

Glass panes or paneling used in windows and doors.

Grade

The term used when referring to the ground elevation around a building.

Grade Beam

A concrete beam around the perimeter of a building.

Ground Snow Load

The probable weight of snow on the ground for a specified recurrence interval exclusive of drifts or sliding



snow.

Grout

A mixture of cement, sand and water used to fill cracks and cavities. Sometimes used under base plates or leveling plates to obtain uniform bearing surfaces.

Gusset Plate

A steel plate used to reinforce or connect structural elements.

Gutter

A light gauge metal member at an eave, valley or parapet designed to carry water from the roof to downspouts or drains.

- H -

"H" Section

A steel member with a cross section in the shape of an "H".

Hair Pin

"V" shaped reinforcing steel used to transfer shear in the anchor rods to the concrete floor mass.

Hand-Geared (Crane)

A crane in which the bridge, hoist, or trolley is operated by the manual use of chain and gear without electric power.

Haunch

The deepened portion of a column or rafter designed to accommodate the higher bending moments at such points. (Usually occurs at the intersection of column and rafter.)

Haunch Brace

A diagonal member from the intersection of the column and rafter section of the rigid frame to the eave member to prevent lateral buckling of the haunch.

Header

The horizontal framing member located at the top of a framed opening.

Heating Degree Day (HDD)

The difference in temperature between the outdoor mean temperature over a 24-hour period and a given base temperature. For example, using a base temperature of 65° F a day with 50° F mean temperature has 15 HDD (65-50=15). The annual Heating Degree Days are the sum of the degree days over a calendar year.

Hem

The edge created by folding metal back on itself.

High Strength Bolts

Any bolt made from steel having a tensile strength in excess of 100,000 pounds per square inch.

High Strength Steel

Structural steel having a yield stress in excess of 36,000 pounds per square inch.

Hinged Base

See "Pinned Base".

Hip

The line formed at the intersection of two adjacent sloping planes of a roof.

Hip Roof

A roof that is formed by sloping planes from all four sides.

Hoist

A mechanical lifting device usually attached to a trolley that travels along a bridge, monorail or jib crane. May be chain or electric operated.

Horizontal Guide Rollers

Wheels mounted near the ends of end trucks that roll on the side of the rail to restrict lateral movement of the crane.

Hot-Rolled Shapes

Steel sections (angles, channels, S-shapes, W-shapes, etc.) which are formed by rolling mills while the steel is in a semi-molten state.



Hydrokinetic

Metal panel systems that are designed to “shed water” are referred to as hydrokinetic. Hydrokinetic roof details are typically devoid of sealant and rely on water to freely shed over the joints. Hydrokinetic roof details are not to be used on roof slopes below 3:12.

Hydrostatic

Metal panel systems that are designed to withstand being submersed in water for a period of time are called hydrostatic panels. Hydrostatic roof details rely on sealant to keep water from infiltrating the joints and seams. Hydrostatic roof details can be used at almost any roof slope (1/4:12 minimum).



"I" Beam

See "S" Shape.

IBC

International Building Code.

ICBO

International Conference of Building Officials.

Ice Dam

A buildup of ice that forms a dam on the roof covering along the eave of the building.

IECC

International Energy Conservation Code.

Impact Load

A dynamic load resulting from the motion of machinery, elevators, craneways, vehicles, and other similar moving forces. See Auxiliary Loads.

Impact Wrench

A power tool used to tighten nuts on bolts.

Importance Factor

A factor that accounts for the degree of hazard to human life and damage to property.

Insect Screen

Wire mesh used to prevent insects from entering the building through ventilators, louvers, or other openings.

Insulation

Any material used in building construction to reduce heat transfer.

Internal Pressure

Pressure inside a building caused by wind acting on the building porosity.



Jack Beam

A beam used to support another beam, rafter or truss and eliminate a column support.

Jack Truss

A truss used to support another beam, rafter or truss and eliminate a column support.

Jamb

The vertical framing members located at the sides of an opening.

Jib Crane

A cantilevered or suspended beam with hoist and trolley. This lifting device may pick up loads in all or part of a circle around the column to which it is attached.

Jig

A device used to hold pieces of material in a certain position during fabrication.

Joist

Light beam for supporting a floor or roof.



- K -

Kick-Out (Elbow) (Turn-Out)

An extension attached to the bottom of a downspout to direct water away from a wall.

Kip

A unit of measure equal to 1,000 pounds.

Knee

The connecting area of a column and rafter of a structural frame such as a rigid frame.

Knee Brace

A diagonal member at a column and rafter intersection designed to resist horizontal loads.

Knee Cap

A metal cover trim that fits over a panel rib or seam area after it has been cut and bent at a fascia break detail.

- L -

Lap Joint

A joint where one roof panel or flashing segment overlaps another.

Lean-To

A structure having only one slope and depending upon another structure for partial support.

Length

The dimension of the building measured perpendicular to the main framing from end wall to end wall.

Leveling Plate

A steel plate used on top of a foundation or other support on which a structural column can rest.

Lift (Crane)

Maximum safe vertical distance through which the hook, magnet, or bucket can move. Also referred to as "Hook Height"

Lifting Devices (Crane)

Buckets, magnets, grabs and other supplemental devices, the weight of which is to be considered part of the rated load, used for ease in handling certain types of loads.

Liner Panel

A metal panel attached to the inside flange of the girts or inside of a wall panel.

Live Load

See "Roof or Floor Live Load".

Load Indicating Washers

A washer with dimples which flatten when the high strength bolt is tightened. The bolt tension can then be determined by the use of feeler gages to determine the gap between the washer and the bolt head.

Longitudinal

The direction parallel to the ridge or sidewall.

Longitudinal (Crane)

Direction parallel to the crane runway beams.

Louver

An opening provided with fixed or movable, slanted fins to allow flow of air.

Low Rise Building

A description of a class of buildings usually less than 60' eave height. Commonly, they are single story, but do not exceed 4 stories.

LRFD

Load and Resistance Factor Design.

- M -



Main Frame

An assemblage of rafters and columns that support the secondary framing members and transfer loads directly to the foundation.

Main Wind Force Resisting System

A structural assembly that provides for the overall stability of the building and receives wind loads from more than one surface. Examples include shear walls, diaphragms, rigid frames, and space structures.

Mansard

A steep sloped (almost vertical) real or mock roof element on the perimeter of a building. Originated by the French architect, Francois Mansart.

Manufacturer

A party who designs and fabricates a Metal Building System.

Manufacturer's Engineer

An engineer employed by a manufacturer who is in responsible charge of the structural design of a Metal Building System fabricated by the manufacturer. The manufacturer's engineer is typically not the Engineer of Record.

Masonry

Anything constructed of materials such as bricks, concrete blocks, ceramic blocks, and concrete.

Mastic

See "Sealant".

Material Safety Data Sheet (MSDS)

A written description of the chemicals composing a product, and other information, such as safe handling and emergency procedures. In accordance with OSHA regulations, it is the manufacturer's responsibility to produce an MSDS and the employer's responsibility to communicate its contents to employees.

MBMA

Metal Building Manufacturers Association.

MCA

Metal Construction Association.

Mean Roof Height

Average height of roof above ground.

Metal Building System

A complete integrated set of mutually dependent components and assemblies that form a building including primary and secondary framing, covering and accessories, and are manufactured to permit inspection on site prior to assembly or erection.

Mezzanine

An intermediate level between floor and ceiling occupying a partial area of the floor space.

Mill Duty Crane

Cranes with service classification E and F as defined by CMAA.

Miter

The joint produced by joining two diagonally cut pieces, or the act of making such a cut.

Model Codes

A building code that is accepted in a large number of states. (See Building Codes.)

Moment

The tendency of a force to cause rotation about a point or axis.

Moment Connection

A connection designed to transfer moment as well as axial and shear forces between connecting members.

Moment of Inertia

A physical property of a member, which helps define strength and deflection characteristics.

Monolithic Construction

A method of placing concrete grade beam and floor slab together to form the building foundation without forming and placing each separately.

Monorail Crane

A crane where the hoist and trolley ride on a single S-shaped runway beam. Similar to an underhung



crane, except a Monorail has only one runway beam and no bridge span and is limited to movement in one axis.

Multi-Gable Building

Buildings consisting of more than one gable across the width of the building.

Multi-Span Building

Buildings consisting of more than one span across the width of the building. Multiple gable buildings and single gable buildings with interior columns are examples.

Multiple Girder Crane

A crane that has two or more girders for supporting the lifted load.

- N -

NAIMA

North American Insulation Manufacturers Association.

NASPEC

North American Specification for the Design of Cold-Formed Steel Structural Members (an AISI Standard).

NBC

National Building Code.

Neoprene

A synthetic rubber (polychloroprene) used in liquid-applied and sheet-applied elastomeric roof membranes or flashings. Also once used as gasketing material beneath the head of metal screw fasteners (although most now use EPDM).

Newton

SI unit of measure for force (N).

Noble

Cathodic.

Non-Structural Panel

Panels which are not generally designed to carry loads and are not normally capable of spanning between structural supports without benefit of substrate materials such as wood, metal or concrete decks. Applied snow, dead, live, concentrated and wind loads are resisted by the support substrate.

- O -

Oil Canning

A waviness that may occur in flat areas of light gage, formed metal products. Structural integrity is not normally affected by this inherent characteristic and therefore is only an aesthetic issue.

Open Web Steel Joists

Light weight truss.

Order Documents

The documents normally required by the Manufacturer in the ordinary course of entering and processing an order.

OSB

Oriented Strand Board (OSB) is composed of rectangular-shaped wood strands which are cross-oriented, compressed, and glued together with waterproof adhesives. OSB is often used in both residential and non-residential construction, such as floors, walls and roof sheathing. Note: Particle Board is not considered OSB, and should not be used in roofing applications.

Outrigger

See "Auxiliary Crane Girder".

Overhanging Beam

A simply supported beam that extends beyond its support.

Overhead Doors

See "Sectional Overhead Doors".



- P -

Pan

The bottom flat part of a roof panel, which is between the ribs of the panel.

Pan Panel

A panel that has a broad flat surface with vertical sides and no space between the edge profile.

Panel Notch

A notch or block out formed along the outside edge of the floor slab to provide support for the wall panels and serve as a closure along their bottom edge.

Panels

See "Cladding".

Parapet

That portion of the vertical wall of a building that extends above the roof line.

Parts and Portions

See "Components and Cladding".

Pascal

SI unit of measure for force per unit area (N/m^2).

Peak

The uppermost point of a gable.

Peak Sign

A sign attached to the peak of the building at the endwall identifying the building manufacturer.

Pendant-Operated Crane

Crane operated from a pendant control unit suspended from the crane.

Personnel Doors

A swinging door used by personnel for access to and exit from a building.

Piece Mark

A number given to each separate part of the building for erection identification. Also called mark number and part number.

Pier

A concrete structure designed to transfer vertical load from the base of a column to the footing.

Pig Spout

A sheet metal section designed to direct the flow of water out through the face of the gutter rather than through a downspout.

Pilaster

A reinforced or enlarged portion of a masonry wall to provide support for roof loads or lateral loads on the wall.

Pinned Base

A column base that is designed to resist horizontal and vertical movement, but not rotation.

Pin Connection

A connection designed to transfer axial and shear forces between connecting members, but not moments.

Pitch

The peak height of a gabled building divided by its overall span.

Pittsburgh Lock Seam

A method of interlocking metal sheets where each of two sheets are folded with two 180° bends.

Plastic Design

A design concept based on multiplying the actual loads by a suitable load factor, and using the yield stress as the maximum stress in any member, and taking into consideration moment redistribution.

Plastic Panels

See "Translucent Light Panels".

Ponding

1. The gathering of water at low or irregular areas on a roof.
2. Progressive accumulation of water from deflection due to rain loads.



Pop Rivet

See "Blind Rivet".

Porosity

Openings in buildings which allow air to enter during a wind storm.

Portal Frame

A rigid frame so designed that it offers rigidity and stability in its plane. It is generally used to resist longitudinal loads where other bracing methods are not permitted.

Post

See "Column".

Post and Beam

See "Beam and Column".

Posttensioning

A method of prestressing reinforced concrete in which tendons are tensioned after the concrete has reached a specific strength.

Power Actuated Fastener

A device for fastening items by the utilization of a patented device which uses an explosive charge or compressed air to embed the pin in the concrete or steel.

Pre-Painted Coil

Coil of metal that has received a paint coating.

Press Brake

A machine used in cold-forming metal sheet or strip into desired sections.

Prestressed Concrete

Concrete in which internal stresses of such magnitude and distribution are introduced that the tensile stresses resulting from the service loads are counteracted to a desired degree; in reinforced concrete the prestress is commonly introduced by tensioning the tendons.

Pretensioning

A method of prestressing reinforced concrete in which the tendons are tensioned before the concrete has been placed.

Primary Framing

See "Main Frame".

Prismatic Beam

A beam with uniform cross section.

Public Assembly

A building or space where 300 or more persons may congregate in one area.

Purlin

A horizontal structural member that supports roof covering.

- Q -

- R -

Rafter

The main beam supporting the roof system.

Raggle

A groove or slot, often cut in a masonry wall or other vertical surface adjoining a roof, for inserting an inset flashing component such as a reglet.

Rail (Crane)

See "Crane Rail".

Rails (Door)

The horizontal stiffening members of framed and paneled doors.



Rake

The intersection of the plane of the roof and the plane of the endwall.

Rake Angle

Angle fastened to purlins at rake for attachment of endwall panels.

Rake Trim

A flashing designed to close the opening between the roof and endwall panels.

Rated Capacity (Crane)

The maximum load (usually in tons) that the crane is designed to support safely.

Reactions

The resisting forces at the column bases holding the structure in equilibrium under a given loading condition.

Reglet

A sheet metal receiver for the attachment of counterflashing, or the counterflashing itself when mounted to a wall. (A reglet may be inset into a raggie, embedded behind cladding, or be surface mounted.)

Reinforcing Steel

The steel placed in concrete as required to carry the tension, compression and shear stresses.

Remote-Operated Crane

A crane controlled by an operator not in a pulpit or in the cab attached to the crane, by any method other than pendant or rope control.

Retrofit

The placing of new metal roof or wall systems over deteriorated roofs or walls.

Rib

The longitudinal raised profile of a panel that provides much of the panel's bending strength.

Ribbed Panel

A panel that has ribs with sloping sides and forms a trapezoidal shaped void at the side lap.

Ridge

The horizontal line formed by opposing sloping sides of a roof running parallel with the building length.

Ridge Cap

A transition of the roofing materials along the ridge of a roof; sometimes called ridge roll or ridge flashing.

Rigid Board Insulation

Typically, a rigid polyisocyanurate or polystyrene foam insulation.

Rigid Connection

See "Moment Connection".

Rigid Frame

A structural frame consisting of members joined together with moment connections so as to render the frame stable with respect to the design loads, without the need for bracing in its plane.

Rolling Doors

Single or multiple leaf doors that open horizontally and are supported at the bottom on wheels that run on a track.

Roll-up Door

A door that opens by traveling vertically.

Roof Assembly

All roof/ceiling components of the building envelope that are horizontal or sloped at an angle less than 60 degrees from horizontal.

Roof Covering

The exposed exterior roof surface consisting of panels.

Roof Curb

See "Curb, Roof"

Roof Jack

1. A synthetic rubber boot or collar that is used to seal around round roof projections. (Also see "Flashing Collar".)
2. A metal bracket used to support toe-boards on steep-slope roofs.



Roof Live Load

Loads that are produced (1) during maintenance by workers, equipment, and materials, and (2) during the life of the structure by movable objects and do not include wind, snow, seismic or dead loads.

Roof Overhang

A roof extension beyond the end wall or side wall of a building.

Roof Seamer

A machine that crimps or folds adjacent edges of standing seam metal roof panels together, to form a seam.

Roof Slope

The tangent of the angle that a roof surface makes with the horizontal, usually expressed in units of vertical rise to 12 units of horizontal run.

Roof Snow Load

That load induced by the weight of snow on the roof of the structure. Usually obtained by taking a fraction of the "Ground Snow Load".

Ropeseal

See "Butyl Tape".

Runway Beam

See "Crane Runway Beam".

Runway Bracket

A bracket attached to the column of a building frame which supports the runway beam for top-running cranes.

Runway Conductors

The main conductors mounted on or parallel to the runway that supplies electric current to the crane.

R-value (Thermal Resistance)

The reciprocal of the U-factor (thermal transmittance). Units of R and $\text{h}\cdot\text{ft}^2/\text{Btu}$. Higher R-values indicate a material's ability to resist more heat flow.

- S -

"S" Shape

A hot rolled beam with narrow tapered flanges.

Sag Member

A tension member such as rods, straps or angles used to limit the deflection of a girt or purlin in the direction of its weak axis.

Sandwich Panel

A panel used as covering consisting of an insulating core material with inner and outer metal skins.

SBCCI

Southern Building Code Congress International, Inc.

Screen Wall

A nonstructural wall erected around units or curbs on a roof. Typically the framing consists of girts with a wood or metal covering attached to the frame.

Screwed Down Roof System

See "Through-Fastened Roof System".

Scupper

An opening in a gutter or parapet wall that allows excess water to escape.

Sealant

A single-or multi-component polymeric or bituminous-based material used to weatherproof construction joints where moderate movement is expected. The material comes in various grades: pourable, self-leveling, non-sagging, gun grade, and tapes.

Seam

1. The joint (sidelap) area formed by connecting two adjacent roof panels.
2. A joint formed by mating two separate sections of material.



Seaming Machine

A mechanical device that is used to close and seal the side seams of standing seam roof panels.

Secondary Framing

Members that carry loads from the building surface to the main framing. For example— purlins and girts.

Section Modulus

A geometric property of a structural member. It is used in design to determine the flexural strength of a member.

Sectional Overhead Doors

Doors constructed in horizontally hinged sections. They are equipped with springs, tracks, counter balancers, and other hardware that roll the sections into an overhead position, clear of the opening.

Seismic Load

The lateral load acting in any horizontal direction on a structural system due to the action of an earthquake.

Self Drilling Screw

A fastener that combines the functions of drilling and tapping.

Self Tapping Screw

A fastener that taps its own threads in a predrilled hole.

Shear

The force tending to make two contacting parts slide upon each other in opposite directions parallel to their plane of contact.

Shear Diaphragm

See "Diaphragm".

Sheet Metal Flashing

See Metal Flashing

Shim

A piece of steel used to level base plates or align columns or beams.

Shipping List

See "Bill of Materials".

Shop Primer Paint

The initial coat of primer paint applied in the shop.

Shot Pin

See "Power Actuated Fastener".

Shoulder Bolt

A fastener used to attach wall and roof paneling to the structural frame. It consists of a large diameter shank and a small diameter stud. The shank provides support for the panel rib.

SI

The International System of Units. Also known as the metric system.

Side Lap Fastener

A fastener used to connect panels together at their side lap.

Sidesway

See "Drift (Sidesway)".

Side Wall

An exterior wall that is perpendicular to the frames of a building system.

Side Wall Overhang

See "Roof Overhang".

Sill

The bottom horizontal framing member of a wall opening such as a window or door.

Sill Angle

See "Base Angle".

Simple Connection

See "Pin Connection".

Simple Span

A term used in structural design to describe a beam support condition at two points which offers no



resistance to rotation at the supports.

Single Slope

A sloping roof in one plane. The slope is from one wall to the opposite wall.

Single Span

A building or structural member without intermediate support.

Single Standing Seam

A standing seam that utilizes one overlapping interlock between two panels.

Siphon Break

A small groove to arrest the capillary action of two adjacent surfaces. (Anti-Capillary Groove).

Sister Column

See "Crane Support Column".

Skylight

A roof accessory to admit light, normally mounted on a curbed framed opening.

Slide Door

A single or double leaf door that opens horizontally by means of sliding on an overhead trolley.

Sliding Clip

A standing seam roof system hold down clip which allows the roof panel to move independently of the roof substructure.

Slope

See "Roof Slope".

SMACNA

Sheet Metal and Air Conditioning Contractors National Association.

Snap-on Cap

A cap that snaps over the vertical legs of some single standing or batten seam metal roof systems.

Snow Drift

See "Drift (Snow)".

Snow Load

See "Roof Snow Load".

Snug Tight

The tightness of a bolt in a connection that exists when all plies in a joint are in firm contact.

Soffit

A material that covers the underside of an overhang.

Soffit Vent

A pre-manufactured or custom built air inlet located in the soffit of a roof assembly.

Soil Pressure

The load per unit area a structure will exert through its foundation on the soil.

Solar Reflectance

The ratio of the reflected solar flux to the incident solar flux.

Solar Spectrum

Radiation originating from the sun, including ultraviolet, visible, and near-infrared radiation. Approximately 99% of solar energy lies between wavelengths of 0.3 to 3.5 micrometers.

1. Ultraviolet (UV) 3% of total energy (responsible for sunburn)
2. Visible (VIS) 40% of total energy (visible light)
3. Infrared (IR) 57% of total energy (felt as heat)

Soldier Column

An intermediate column used to support secondary structurals; not part of a main frame or beam and column system.

Spacer Strut (Crane)

A type of assembly used to keep the end trucks of adjacent cranes on the same runway beams a minimum specified distance apart.

Spall

A chip or fragment of concrete that has chipped, weathered or otherwise broken from the main mass of concrete.



Span

The distance between supports of beams, girders, or trusses.

Specification (Metal Building System)

A statement of a set of Metal Building System requirements describing the loading conditions, design practices, materials and finishes.

Splice

A connection in a structural member.

Splice Plate

1. See "Butt Plate"
2. In Roofing, a metal plate placed underneath the joint between two sheets of metal.

Spud Wrench

A tool used by erectors to line up holes and to make up bolted connections; a wrench with a tapered handle.

Square

1. The term used for an area of 100 square feet.
2. A 90° angle.

Stainless Steel

An alloy of steel that contains a high percentage of chromium to increase corrosion resistance. Also may contain nickel or copper.

Standing Seam

Side joints of roof panels that are arranged in a vertical position above the drainage plane of the panels or flashings.

Standing Seam Roof System

A standing seam roof system is one in which the side laps between the roof panels are arranged in a vertical position above the roof line. The roof panel system is secured to the roof substructure by means of concealed hold down clips attached with screws to the substructure, except that through fasteners may be used at limited locations such as at ends of panels and at roof penetrations.

Stiffener

1. A member used to strengthen a plate against lateral or local buckling. Usually a flat bar welded perpendicular to the longitudinal axis of the member.
2. A formed shape in a metal panel that reduces the effect of oil canning in the panel's flat area. Sometimes called "stiffener rib", or "stiffener flute".

Stiffener Lip

A short extension of material at an angle to the flange of cold formed structural members, which adds strength to the member.

Stiles

The vertical side members of framed and paneled doors.

Stitch Screw

A fastener connecting panels together at the sidelap.

Straight Tread Wheels

Crane wheels with flat machined treads and double flanges which limit the lateral movement of the crane.

Strain

The deformation per unit length measured in the direction of the stress caused by forces acting on a member. Not the same as deflection.

Stress

A measure of the load on a structural member in terms of force per unit area.

Structural Panel

A panel that is capable of spanning between structural supports and can resist snow, dead, live, concentrated and wind loads without the benefit of any substrate material.

Strut

A member fitted into a framework that resists axial compressive forces.

Stud

A vertical wall member to which exterior or interior covering or collateral material may be attached. May



be either load bearing or non-load bearing.

Substrate

The surface upon which the roofing or waterproofing membrane is placed (i.e. structural deck, plywood or insulation).

Suspension System

The system (rigid or flexible) used to suspend the runway beams of underhung or monorail cranes from the rafter of the building frames.

Sustainability

"Meeting the needs of present generations without compromising the ability of future generations to meet their needs." – The World Commission on Environment and Development, 1987 (U.N. Brundtland Report).

Sweep

The amount of deviation of straightness of a structural section measured perpendicular to the web of the member.

- T -

Tapered Members

A built up plate member consisting of flanges welded to a variable depth web.

Tapered Tread Wheels

End truck wheels with treads that are tapered, the large diameter being toward the center of the span.

Temperature Reinforcing

Light weight deformed steel rods or wire mesh placed in concrete to resist possible cracks from thermal expansion or contraction.

Tensile Strength

The longitudinal pulling stress a material can bear without tearing apart.

Tension Forces

Forces acting on a member tending to elongate it.

Thermal Block

A thermal insulating material that is placed between the metal building roof and the compressed insulation over the purlins. Also known as a "thermal spacer block".

Thermal Conductance (C-factor)

The time rate of heat flow through unit area of a body induced by unit temperature difference between the body surfaces. Units for C are Btu / (ft² × °F) [Imperial system] or Watts / (m² × °K) [SI system]. See "Thermal resistance".

Thermal Conductivity (K-factor)

The time rate of heat flow through unit thickness of a flat slab of a homogenous material in the perpendicular direction to the slab surfaces induced by unit temperature gradient. Units for K are Btu / hour / °F [Imperial system] or Watts / hour / °K [SI system]. See "Thermal resistivity".

Thermal Emittance

The ratio of the radiant heat flux emitted by a sample to that emitted by a blackbody radiator at the same temperature. (Total Thermal Emittance). Values are expressed from 0 to 1.0, with 1.0 being the maximum emittance possible.

Thermal Movement

The expansion and contraction that occurs in materials due to temperature change.

Through Ties

Reinforcing steel, usually in the concrete, extending from one column pier to the other column pier, tying the two columns of a rigid frame together to resist thrust.

Through-Fastened Roof System

A through-fastened roof system is one in which the roof panels are attached directly to the roof substructure with fasteners which penetrate through the roof sheets and into the substructure.

Thrust

The horizontal component of a reaction usually at the column base.



Tie

A structural member that is loaded in tension.

Ton

2000 pounds.

Torque Wrench

A wrench containing an adjustable mechanism for measuring and controlling the amount of torque or turning force to be exerted – often used in tightening nuts and bolts.

Track

A metal way for wheeled components; specifically, one or more lines of ways, with fastenings, ties, etc., for a craneway, monorail or slide door.

Translucent Light Panels

Panels used to admit light.

Transverse

The direction parallel to the main frames.

Trapezoidal Panel

A panel configuration whose edge profile forms an open geometric form, roughly in the shape of a trapezoid.

Tributary Area

The area directly supported by the structural member between contiguous supports.

Trim

The light gauge metal used in the finish of a building, especially around openings and at intersections of surfaces. Often referred to as flashing. When contrasted, "trim" is generally more decorative, while "flashing" serves more as functional weatherproofing.

Trolley (Crane)

The unit carrying the hoisting mechanism.

Trolley Frame (Crane)

The basic structure of the trolley on which are mounted the hoisting and traversing mechanisms.

Truss

A structure made up of three or more members, with each member designed to carry a tension or compression force. The entire structure in turn acts as a beam.

Turn-of-the-Nut Method

A method for pre-tensioning high strength bolts. The nut is turned from the "Snug tight" position, corresponding to a few blows of an impact wrench or the full effort of a man using an ordinary spud wrench, the amount of rotation required being a function of the bolt diameter and length.

Turnout

See "Kick-Out".

Twist Off Bolts

Bolts with a segment which shears off at a predetermined torque during bolt tightening. These bolts utilize a specially designed wrench for proper installation.

- U -

UBC

Uniform Building Code.

Underlayment

A secondary waterproofing sheet material installed between the substrate and the roof panels, usually used in hydrokinetic roof construction. Some types may be self-adhering.

Uplift

1. See "Wind Uplift"
2. Upward force at a column base caused by applied building loads or building geometry.

Urban Heat Island

A built environment wherein the large proportion of dark surfaces such as asphalt paving and dark roofs absorb solar radiation and radiate the heat back into the atmosphere causing higher ambient temperatures



and higher pollution levels.

U-Value (U-Factor)

Heat transmission in unit time through unit area of a material or construction and the boundary air films, induced by unit temperature difference between the environments on each side. Units of U are Btu / (hour × ft²). A lower U-value, means less heat flow that occurs through an assembly from the warm side to the cooler side.

- V -

Valley

An architectural detail created where two roof planes intersect, usually having ridge lines at right angles to each other.

Valley Gutter

A channel used to carry off water from the "V" of roofs of multi-gabled buildings.

Vapor Barrier

Material used to retard the flow of vapor or moisture to prevent condensation from forming on a surface.

Variiegated Roof Surface

A surface marked with patches, spots or areas of different colors. In contrast to a surface having either one color or a regular pattern or texture, a variegated surface has a varied design of several colors and/or textures.

Vent

An opening designed to exhaust air, heat, water vapor or other gas from a building or a building component to the atmosphere.

Ventilation

The process of supplying or removing air by natural or mechanical means to or from any space.

Ventilator

An accessory usually used on the roof that allows the air to pass through.

- W -

"W" Shape

A hot rolled member with parallel flanges.

Wainscot

Wall material used in the lower portion of a wall that is different from the material in the rest of the wall.

Walk Door

See "Personnel Door".

Wall Covering

The exterior wall surface consisting of panels or other material.

Web

That portion of a structural member between the flanges.

Web Member

A secondary structural member interposed between the top and bottom chords of a truss.

Web Stiffener

See "Stiffener".

Wheel Base

Distance from center-to-center of outermost crane wheels.

Wheel Load

The vertical force without impact produced on a crane wheel bearing on a runway rail or suspended from a runway beam. Maximum wheel load occurs with the crane at rated capacity and the trolley positioned to provide maximum vertical force at one set of wheels.

Width

The dimension of the building measured parallel to the main framing from sidewall to sidewall.



Wind Bent

See "Portal Frame".

Wind Column

A vertical member designed to withstand horizontal wind loads.

Wind Load

The load caused by the wind from any horizontal direction.

Wind Uplift

The differential pressure resulting from the deflection of wind at roof edges, roof peaks or obstructions, causing a drop in air pressure immediately above the roof surface. This pressure, combined with "Internal Pressure", produces an upward force on the roof components. In "Built-Up Roofing", wind uplift may also occur because of the introduction of wind pressure underneath the membrane and roof edges, where it can cause the membrane to balloon and pull away from the deck.

- X -

X-Bracing

Bracing system with members arranged diagonally in both directions to form an "X". See "Bracing".

- Y -

- Z -

"Z" Section

A member cold formed from steel sheet in the shape of a "Z".

Zinc-Aluminum Coated

Steel coated with an alloy of zinc and aluminum to provide corrosion resistance.